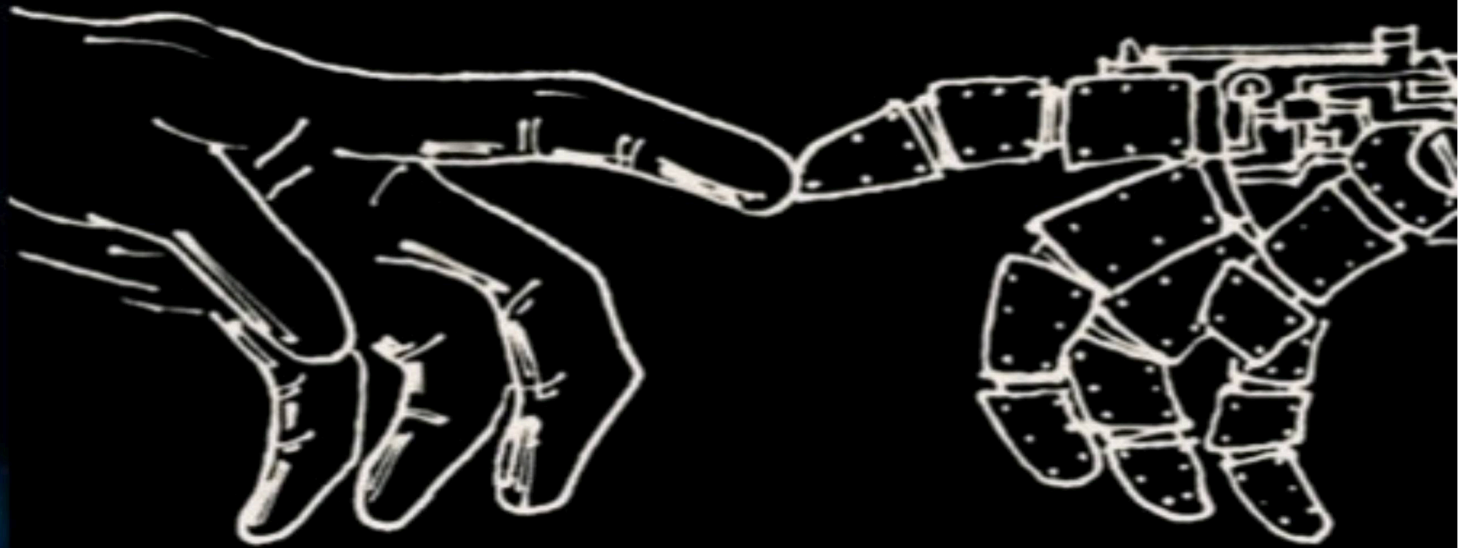


# DEPARTMENT OF BIOMEDICAL ENGINEERING



**SSN**

## ABOUT SSN

### OVERVIEW

ABOUT SSN  
ABOUT BME DEPARTMENT  
CURRICULUM  
INFRASTRUCTURE  
'-ATHONS'  
ABE INAUGURAL  
IEEE EMBS STUDENT CHAPTR  
SNU VISIT  
SOCIALLY RELEVANT PROJECTS  
INNOVATIVE DESIGN  
CONTRIBUTIONS TO HEALTH CARE  
ICBSII'20  
ACADEMIC COLLABORATIONS  
SEMINARS AND WORKSHOPS  
TECHNICAL ACTIVITIES  
EXTRA CURRICULAR AND CO-CURRICULAR ACTIVITIES  
INTERNAL FUNDED PROJECTS  
PATENTED PROJECTS  
JOURNAL PUBLICATIONS  
MOUs and HIGHER EDUCATION  
ALUMNI ACHIEVEMENTS  
ALUMNI TALK  
TESTIMONIALS

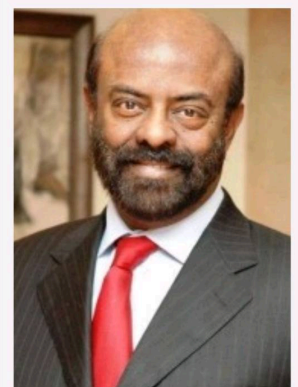
SSN Institutions, founded by Dr. Shiv Nadar, Chairman, HCL Technologies, stands out as a premier centre of higher learning with a mission of pursuing excellence in education and research. The institutions, with their diverse and dynamic community of students offer a distinctive combination of some of the finest graduate, undergraduate and research programs, accomplished faculty, world class facilities and a residential campus set on a sprawling 250 acres of sylvan surroundings.

SSN College of Engineering has been ranked 27th by the National Institutional Ranking Framework 2017 released by the Ministry of Human Resources and Development, among all engineering colleges in India. SSN is ranked number one private engineering institution in Teaching, Learning & Resources and 17th among all engineering institutions in the category. SSN is ranked number five among all private engineering institutions in India. SSN College of Engineering has also been accredited by the NAAC with an A+ grade and also by NBA for 5 consecutive years. SSN College had been designated as an Autonomous University in 2018 and later established itself as a state



## ABOUT THE FOUNDER

SSN Institutions was found by Padma Bhushan Dr. Shiv Nadar, Chairman of HCL Technologies. In 1994, Nadar established what he believed was closest to his heart – the philanthropic Shiv Nadar Foundation and created its first initiative in Chennai, the SSN Institutions, that is a top ranked engineering college. Today the Foundation is a significant driver of social change and transformational education through its landmark institutions spanning the entire education spectrum from schools to universities. A young and a unique research led interdisciplinary university, the Shiv Nadar University has been identified



## ABOUT THE DEPARTMENT

The Department of Biomedical engineering reflects the interdisciplinary ideas and offers world class education and research opportunities to students. It was started in the year 2005 offering B.E degree in Biomedical Engineering. The department has been recognised as a research centre in 2011 and offers Ph.D. degree in Biomedical Engineering. It also offers Master of Engineering degree in Medical Electronics, since 2014.

### VISION

The Vision of Biomedical Department is to become a Centre of Excellence in biomedical engineering for the prosperity of the country, ensuring quality health service delivery, education and research.

### MISSION

- To educate students to understand the human body as an integrated system through quantitative engineering analysis and to use that understanding to design better therapeutic strategies, devices, and diagnostics
- To serve society by conducting research that develops quantitative linkages across scales in the human body and uses that development to build new tools to improve human health
- To catalyze interactions between biologists, physical scientists, and engineers to benefit medicine and human health
- To create enabling technologies through innovative and evidence based interventions and practices for the improvement of human health and health care

### FROM THE HOD'S DESK



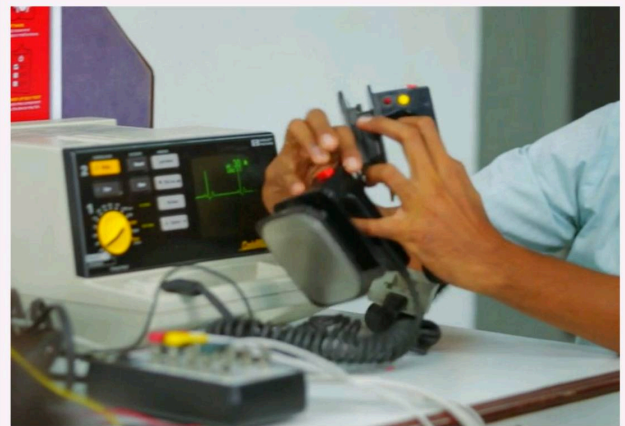
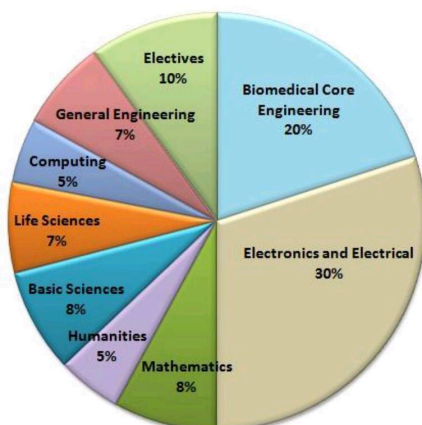
On behalf of the Department of Biomedical Engineering, it is my pleasure to invite you to our beautiful academic campus for conducting campus selection programmes for our students. It is my privilege to mention that this department was established in the year 2005 and over the years it has earned great recognition not only in India but all over the globe. The students of this department are occupying enviable positions in various institutions for higher studies and organizations at home and abroad. The department has earned fame not only for its excellent academic and extracurricular activities, but also for its research and development activities.

A rigorous academic regimen has equipped students with the professional and personal skills to excel in which-ever domain sector they choose to work. All the students recruited from Biomedical Department of SSNCE have proved to be great asset to all organizations they have joined. I am certain that the present graduates would maintain the same level of performance. I wish the on-campus recruitment programme a great success and shall always look forward for mutually beneficial relationship with the recruiters of our graduates.

# ABOUT THE DEPARTMENT

## CURRICULUM

- Sensors and Measurements
- Object Oriented Programming and Data Structures
- Statistics, Transforms, Random Processes
- Anatomy and Human Physiology
- Analog and Digital ICs
- Pathology and Microbiology
- Analog and Digital Communication
- Bio Control Systems
- Diagnostic and Therapeutic Equipment
- Bio Materials and Artificial Organs
- Biomedical Instrumentation
- Microprocessor and Microcontroller
- Medical Physics & Radiological
- Equipment Biomechanics & Biofluids
- Digital Signal Processing & Image
- Processing Pattern Recognition and
- Neural Networks Medical Informatics
- Rehabilitation Engineering and Assist
- Devices Physiological Modelling
- Biometrics
- Soft Computing



## INFRASTRUCTURE

The Department of Biomedical Engineering is equipped with:

- ◆ Bioelectronics Lab
- ◆ Biochemistry Lab
- ◆ Biomedical Instrumentation Lab
- ◆ Medical Software Lab
- ◆ Diagnostic and Therapeutic Lab
- ◆ Pathology and Microbiology Lab
- ◆ Data acquisition Lab
- ◆ Clinic
- ◆ Library

**IEEE COVID-19 HACKATHON**

IEEE India Council organized a 3-day national online IEEE COVID-19 hackathon, from 17th April to 19th April 2020 to develop innovative solutions for the problems caused due to the outbreak of the COVID19 virus. This Pan India event saw more than 500 registrations with 61 teams participating across industries and academia. Among them, 10 were selected as finalists and 4 winners were declared. Team “MedTex” comprising of M.C. Sai Kavya Neharika - 2nd year BME - IEEE member, S. Shwetha - 2nd year ECE, M. Lokesh Kumar - 2nd year BME, Sakthivel Sukeerthi - 2nd year M.E Medical Electronics, bagged the coveted first prize for their project titled “Corover 2020”, under the mentorship of Dr B Geethanjali, Associate Professor, SSN College of Engg. The IEEE authorities are in discussion with concerned authorities to push the idea presented for use by government/public authority.

The esteemed jury members were Mr. Puneet Mishra (Head, Satellite Antenna Characterization, Test & Design Section at U R Rao Satellite Centre/IEEE Bengaluru), Mr. Bala Peddigari (Principal consultant & Technology Head-TCS / IEEE Hyderabad), Dr. Vaibhav Srivastava (Professor-IIT Kanpur/ IEEE UP) and Mr. Girish Khilari (CTO&Director at Elliot Systems/IEEE Pune).

Many studies show that mass sanitization can be done effectively by means of UV-C lamps and disinfectant sprays during this pandemic. The far-UV-C rays alter the RNA of the pathogen and prevent its further multiplication, while aerosol sprays disintegrate the protective lipid coating. The proposed device is a simple robot having four wheels and two motors which can either use far-UV-C-rays to disinfect distances up to 180 cm, or, can spray disinfectant through an ultrasonic nozzle towards specific areas. Since this can be used in the disinfection of large areas, it meets the need for mass sterilization effectively, with minimal cost. An important feature of this product is that it can be used even after the pandemic abates. UV sterilization is very effective and reduces the transmission of four major superbugs by a cumulative 30 percent. The cost for prototype development would be of Two types : Manually controlled (roughly 20,000 - 25000) and Fully Automatic (Approx. 40,000 - 45,000).The improvised automatic bot uses a LIDAR sensor for Navigation . As more features are added, the cost will increase accordingly. It is important to mention that there are existing products in the market offered by companies such as UVD robotics. These pre-existing devices cost around 90,000 to 1,00,000 USD.

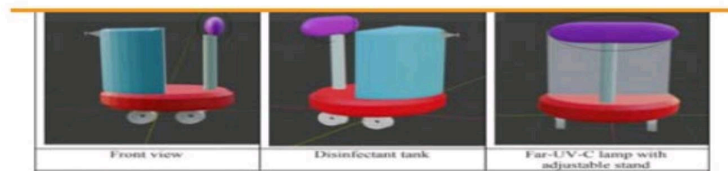
In comparison, this indigenous product is designed to be manufactured within a short time, without compromising on the efficiency, at a fraction of the cost. An option to sterilize isolation wards and waiting rooms using disinfectants, in case of failure of the UVC lamp, is also provided. As of now we have designed a bot for the purpose of disinfection of hospitals and isolation wards. This can further be implemented for sanitisation of Public spaces such as Airports, Malls, Schools.etc. Further applications of this idea could be in Hand held Far UVC devices that can disinfect Groceries and other home utilities. Disinfecting the N-95 and N-99 masks with use of Far UVC can help to reuse the mask, thereby reducing Biomedical waste.

In the hackathon, there was another team that came up with a similar idea, which focused on only sterilizing the floor. It is neither considered if the surrounding equipment and furniture might be contaminated, nor allowed for sterilization using disinfectant.

Shwetha S, the second year ECE student remarked, “It was an exciting experience and it was enlightening to see how different teams devised solutions for the problems caused by the pandemic.”

## This robot by Chennai's SSN College of Engg can sanitise large spaces with UV-C lamps

An option to sterilise isolation wards and waiting rooms using disinfectants, in case of failure of the UV lamp, is also provided in the robot



Corover 2020 | Pic: SSN College of Engg

In the wake of COVID-19 pandemic, a team of students from the **SSN College of Engineering in Chennai**, have used an existing study that mass sanitisation can be done effectively by means of UV-C lamps and disinfectant sprays to come with a solution of disinfecting large areas quickly. Using the same knowledge, the students have developed a robot, **Corover 2020**, that can be used for two purposes — to disinfect distances up to 180 cm using UV-C-rays or spray disinfectant through an ultrasonic nozzle towards specific areas.

Fig. 5.28 Mass sanitation device

## COVID-19 VIRTUAL HACKATHON

A team of students from BME and CSE departments participated in the COVID19 Virtual Hackathon conducted by Rajalakshmi Institute of Technology. The problem statement “Design a simple application which alarms the user if he/she violates the social distancing” and the project won first place. Dr. V. Mahesh ASP/BME and Dr. R. Sundareswaran, ASP/Maths mentored the team. A 24-hour online hackathon was conducted by Rajalakshmi College of Engineering on April 25th 2020. This hackathon focused on solving COVID 19 challenging problems. We, a team of four, made a mobile application to practice safe social distancing. This app alerts the user if he/she violates social distancing. This application works on Bluetooth technology, that constantly searches for Bluetooth devices in its range. Once devices are discovered within the range, an alarm goes off on both devices to alert the user that he/she is violating the safe distance. Also, the app provides information such as the nearby redzones in the user’s region, and a notification is sent to the user when he/she approaches a crowded place, with some guidelines to remain safe and infection-free. Additionally, this app gives the count of people within the distance of 3m and the red zone hotspots.

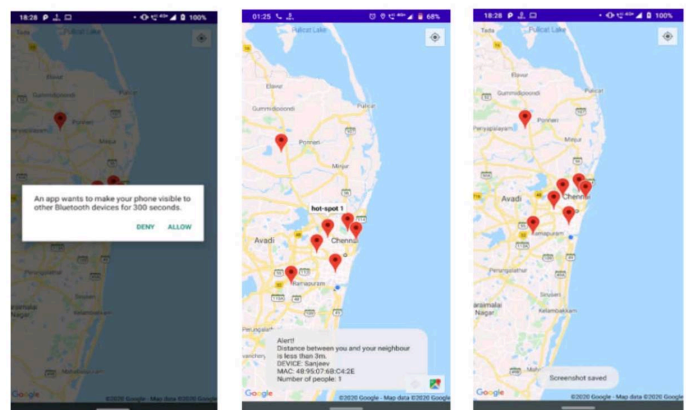
### Team members

Ms.G.Rebecca Maria -II yr BME

Ms.Varsha Seshadri -II yr BME

Mr. Harish Balaji - III yr CSE

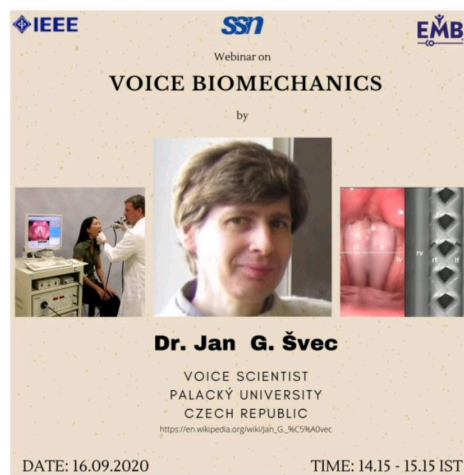
Mr. Amogh Gupta -IIIyr CSE



# IEEE-EMBS STUDENT CHAPTER

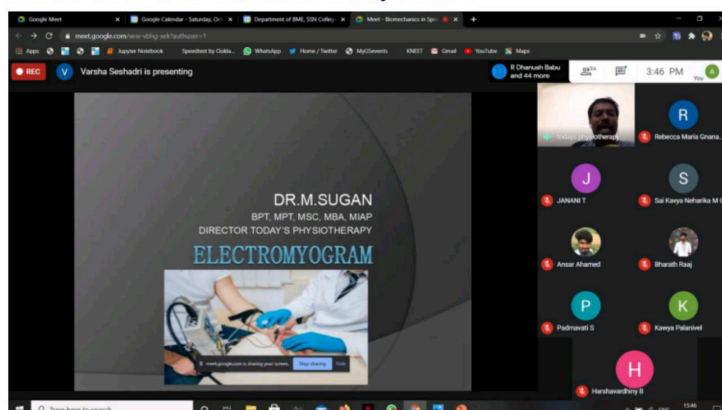
The IEEE—EMBS Student chapter was reinstated on June 1st, 2020. The Office Bearers for the EMBS are Ansar Ahamed (IV year), as the Chair, Rajkumar AJ (IV year), the Co chair, Nanthini R (IV year), the Vice Chair, Varsha Seshari(III year), the Secretary and Rebecca Maria (III year) as the Treasurer. The Faculty Coordinator is Dr. S. Pravin Kumar Associate Professor. A number of successful events were thereafter conducted with a humongous participation from the students.

A Webinar on Voice Biomechanics was conducted by the student body of IEEE-EMBS for the third year students of Department of Biomedical Engineering, SSN College of Engineering. It was a one hour webinar with Jan Švec, Voice Scientist at Palacky University, Czech Republic. Students were taught about the basic biomechanics of human voice production along with real-time demonstrations of how human sounds are processed in the vocal tract using VoceVista 3.3 and Madde softwares. The interesting demonstrations instigated the students to ask doubts about various aspects of human voice and how it is processed in voice recognition systems.



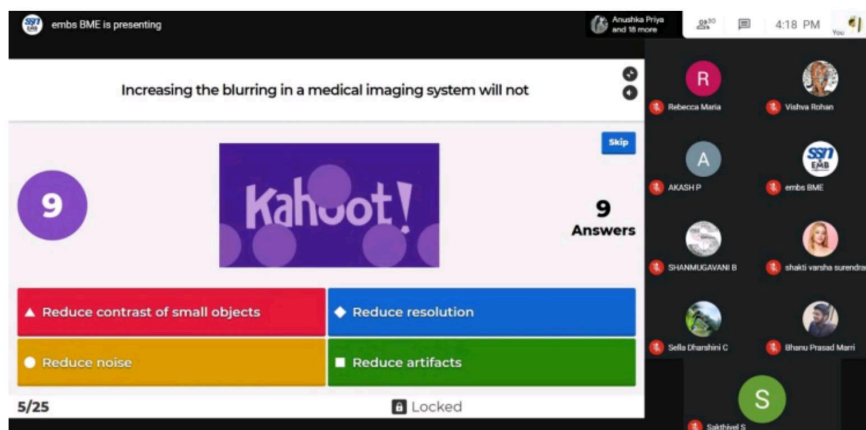
The title of this webinar was “Biomechanics in Sports and Rehabilitation Engineering” and was organized by the student body of SSN-IEEE-EMBS for the 2nd- and 3rd- year students of the Department of Biomedical Engineering. There were also participants from other colleges as well as a student from UNAC, Peru, who is also an IEEE-EMBS member. The webinar began at 3:30pm and went on till

5:30pm. The guest lecturer was Dr. Sugan. M, who is a Neuro-physiotherapist and practices at Today’s Physiotherapy Clinic. He also does a lot of studies and research in EMG analysis in neuropathic individuals. He explained to the students about the basics of EMG signals and went through the basics of the human musculoskeletal system..

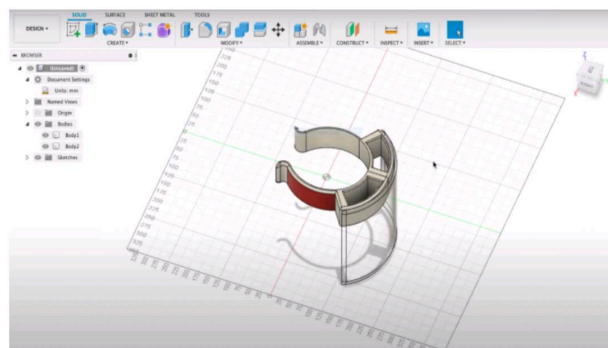
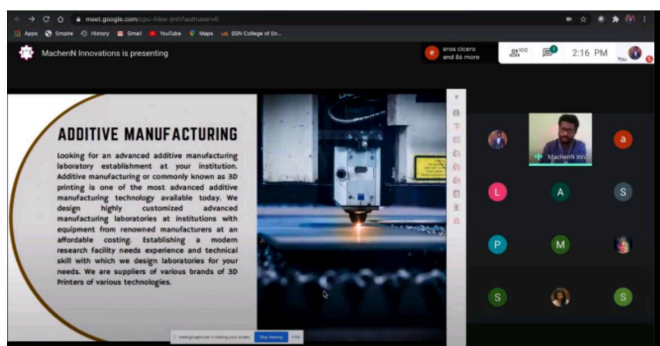


# IEEE-EMBS STUDENT CHAPTER

"Bio-Pedia 1.0" was a quiz event organized by the student body of SSN IEEE EMBS. The topics for the quiz covered gate syllabus namely- anatomy, electrical circuits, analog and digital electronics, biomechanics and medical imaging. Second year and third year biomedical students from different colleges participated. The quiz was held on 30th November from 4pm to 5pm involving 20 active participants from SSN as well as other colleges. Quiz was conducted through "Kahoot". There were a total of 25 questions involving both theory type and calculation type questions. All the questions were time bound and the winners were chosen based on the time taken and number of right answers. Overall, the event went successful. And we received positive feedbacks from the participants.



A Workshop on the basics of 3D-Designing and Modeling was conducted by the student body of IEEE-EMBS for the second and third year students of Department of Biomedical Engineering, SSN College of Engineering. It was a half day workshop with Mr Vishnu TU the founder of Machenn Innovations, Coimbatore addressing the students. Students were taught the basics tools in the 3D-Designing software Fusion 360 by one of our third year student, Lokesh Kumar. Followed by the advanced tool usage and question answer session with our speaker Mr. Vishnu TU. The students' interests were kindled and their feedback was that the workshop was useful to get to know about the designing software and it's tools.

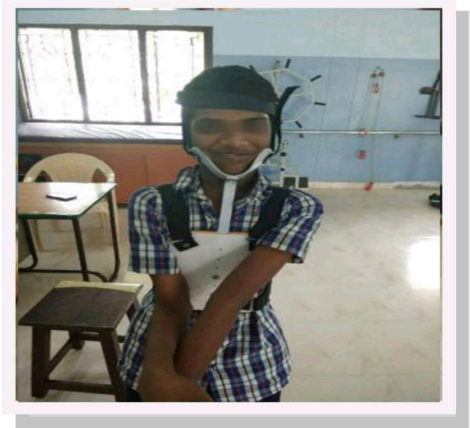




## **SOCIALLY RELEVANT PROJECTS**

### **Cerebral Palsy Head Support**

- ◆ **Project by Vishwanath S and Praveen Kumar (2019)**
- ◆ **Under the guidance of Ms M Dhanalakshmi Assistant Professor, Department of Biomedical Engineering**



### **Orthopedic belt using sodium acetate crystals**

- ◆ **Project by Vishwanath S and Apurva (2019)**
- ◆ **Under the guidance of Dr R Subashini, Assistant Professor, Department of Biomedical Engineering**

### **Prosthetic limbs**

- ◆ **Project by Vaishali, M.E (2015)**
- ◆ **Under the guidance of Dr A Kavitha, Head of the Department of Biomedical Engineering and Ms R Nithya, Assistant Professor, Department of Biomedical Engineering**



# SOCIALLY RELEVANT PROJECTS

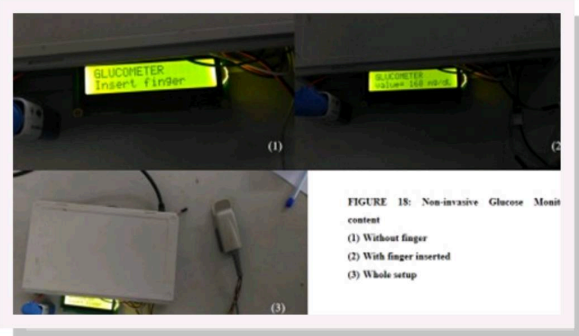
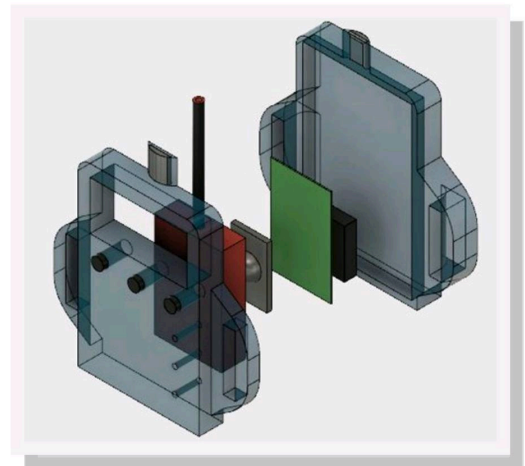


## Mass screening device for osteoarthritis

- ◆ Project by R Abirami, N Meghala and S Tamizhamudham, (2018)

## Electronic Nose for Diagnosis of Tuberculosis

- ◆ Project by Manuj R, Divya Rajagopal and Meghna Murali (2019)
- ◆ Under the guidance of Ms R Nithya, Assistant Professor, Department of Biomedical Engineering



## Non invasive glucose measurement

- ◆ Project by Haripriya and Nagavarshini (2018)
- ◆ Under the guidance of Dr L Suganthi, Assistant Professor, Department of Biomedical Engineering

## Indian Sign language converter using sEMG

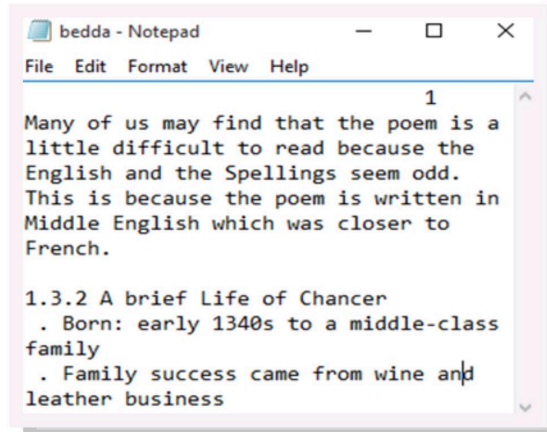
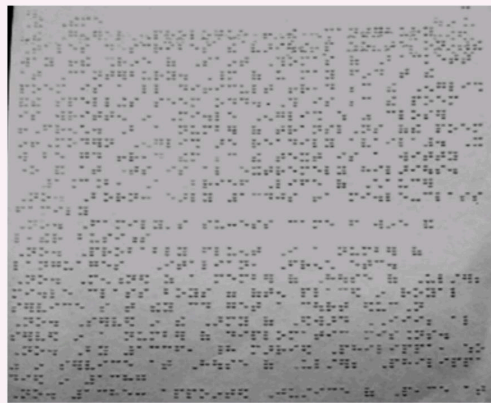
- ◆ Currently being worked on by B Sangeetha (2019)
- ◆ Under the guidance of Ms M Dhanalakshmi, Assistant Professor, Department of Biomedical Engineering



# SOCIALLY RELEVANT PROJECTS

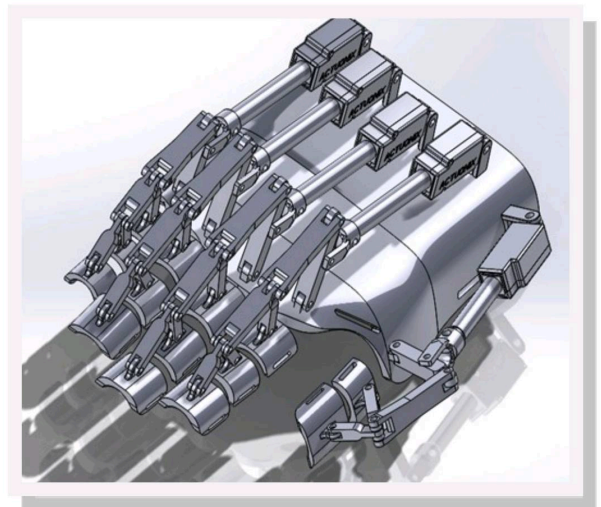
## Braille transliteration for visually impaired

- ◆ Project by Sugirtha, M.E (2015)
- ◆ Under the guidance of Ms M Dhanalakshmi, Assistant Professor, Department of Biomedical Engineering



## Exoskeleton

- ◆ Project by Rathi Adharshi, Shuruthi Sree.R and Santhana Lakshmi.A (2018)
- ◆ Under the guidance of Dr A Kavitha, Head of the Department of Biomedical Engineering



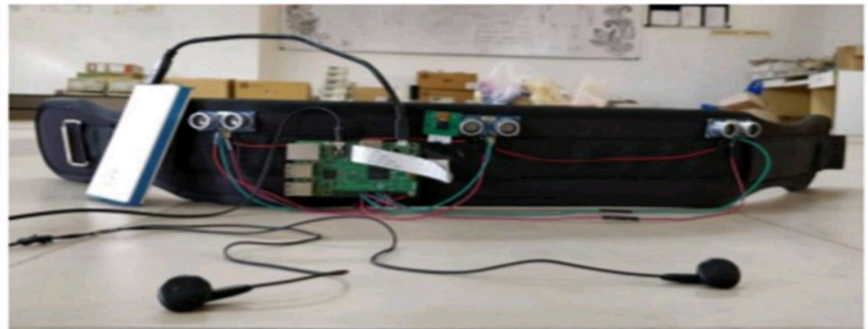
## Low cost dialysis machine

- ◆ Project by Surya Prakash, R Gopichandran and M Vaibhav (2017)
- ◆ Under the guidance of Dr V Mahesh, Associate Professor, Department of Biomedical Engineering

## SOCIALLY RELEVANT PROJECTS

### Outdoor Obstacle Detection Module to Assist Visually Challenged

- ◆ Project by the Gayathri Devi, Anuradha V and Meena Nisha, IV year, BME (2018)
- ◆ Under the guidance of Ms M Dhanalakshmi, Assistant Professor, Department of Biomedical Engineering

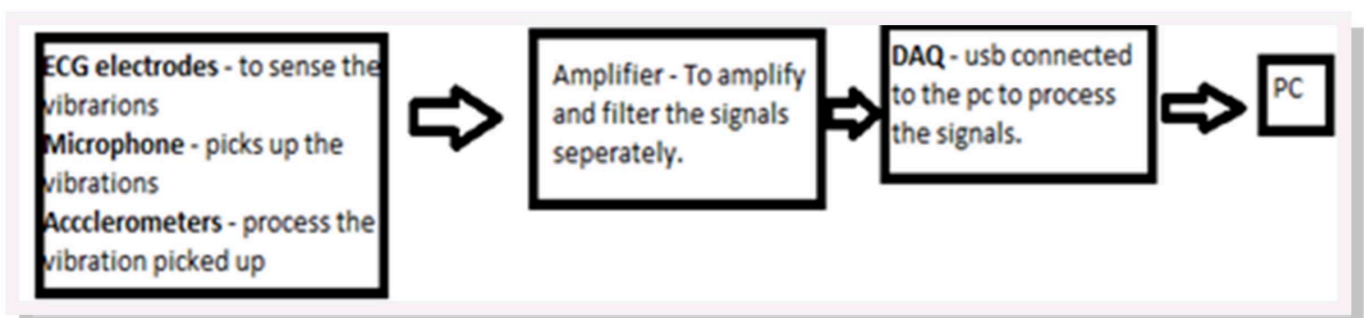


### Virtual Reality for ASD

- ◆ Project initially handled by Deepika and team (2014) and currently being handled by Yaamini D and Vishwath Narayanan (2019)
- ◆ Under the guidance of Dr A Kavitha, Head of the Department of Biomedical Engineering

### Non invasive JVP measurement

- ◆ Project by Kavya Vijaya Kumar, and S Suhashine , III year, BME
- ◆ Under the guidance of Dr S Bagyaraj, Associate Professor, Department of Biomedical Engineering



## SOCIALLY RELEVANT PROJECTS

### A Knee Brace for Genu Recurvatum

- A project titled “A Knee Brace for Genu Recurvatum” was done by Viswanath.S, Praveen Kumar G, Om Prakash S, and Dhanalakshmi M.
- The knee brace supports the knee joint from hyper-extension by maintaining its motion within normal gait pattern range.
- A patent was filed for the project (Application No. 201941031288).
- The knee brace was designed based on a problem statement from Spastics Society of Tamilnadu (SPASTN) and it was donated to kids at SPASTN.



Standing



Walking with walker



Sitting

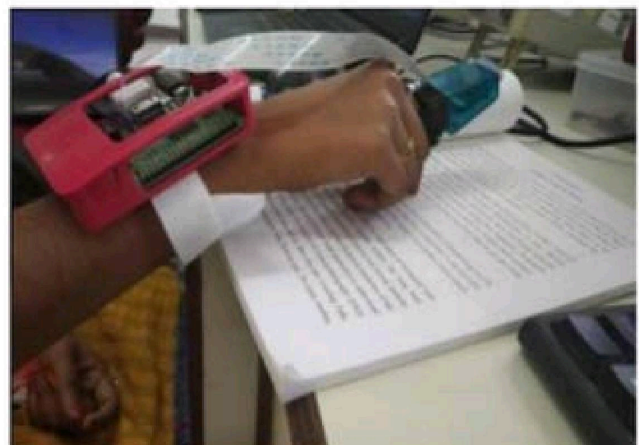


Walking without walker

**Fig. 5.21 Knee brace for Genu Recurvatum**

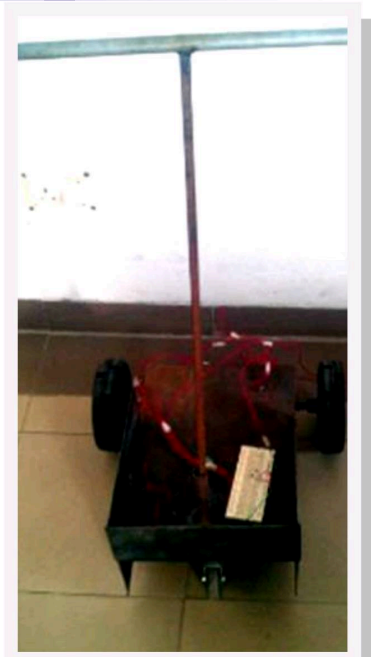
### Wearable Reader for Visually Impaired People

- The project titled “Wearable Reader for Visually Impaired People” was an internally funded student project by SSN trust.
- This device can be worn in hand and gain access to various number of learning resources and can be widely used by the blind people for their studies.
- This project was presented in Project Expo 2k20 (Hardware and Software) - ‘Leveraging Technology for a better tomorrow, and won first place.
- This project was done by Ms. Srija and Ms. Kawya and it was coordinated by Ms. Dhanalakshmi AP/BME

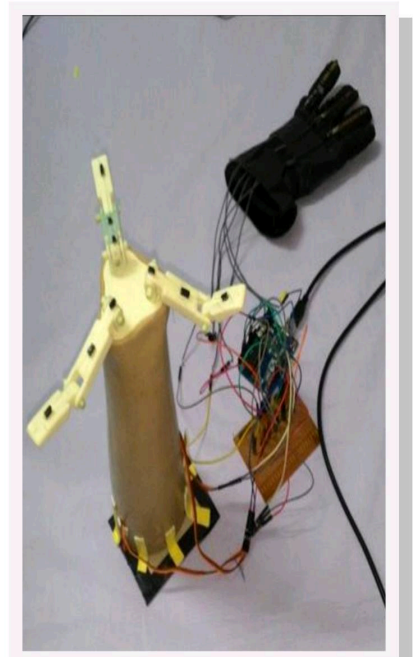


**Fig. 5.27 Wearable reader**

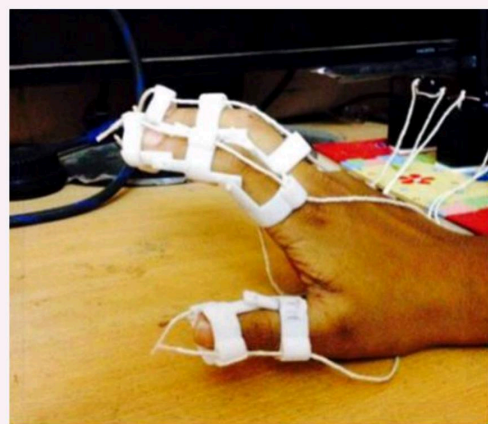
# INNOVATIVE DESIGN CONTRIBUTIONS TO HEALTHCARE



Assist device for visually impaired



Design and Development of Hand Gesture Controlled Robotic Upper Limb Prosthesis



Design of Orthotic Assistive Exoskeleton for Human Hand



Design of Exoskeleton for Lower Extremities



Design of Quasi-passive Orthotic Exoskeleton for Lower Extremity

**IEEE 2021 SEVENTH INTERNATIONAL CONFERENCE ON BIOSIGNALS IMAGES AND INSTRUMENTATION (ICBSII 2021)**

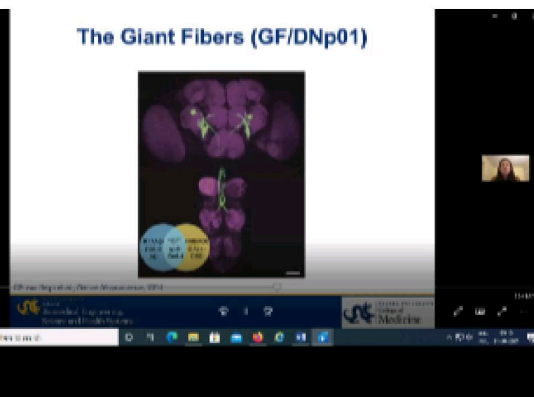
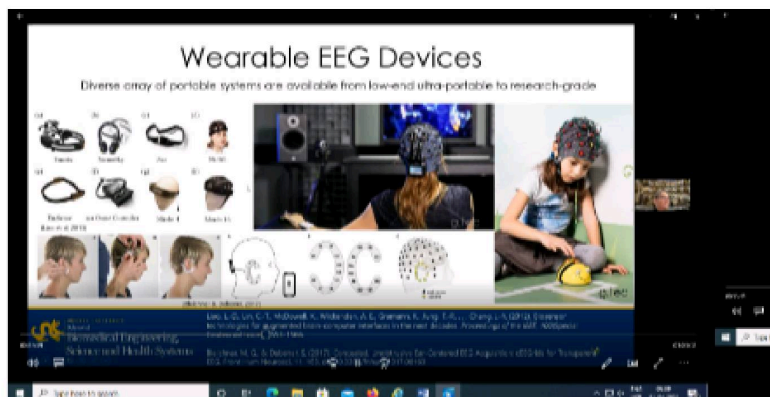
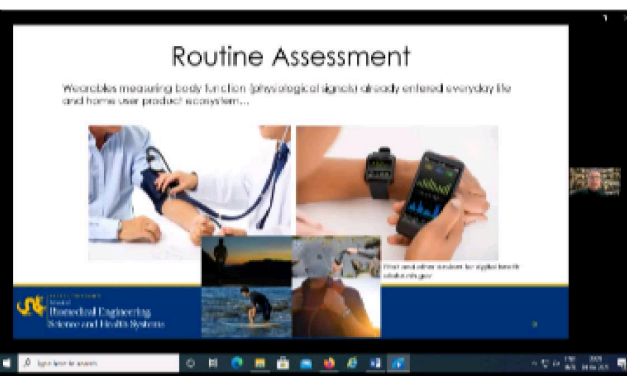
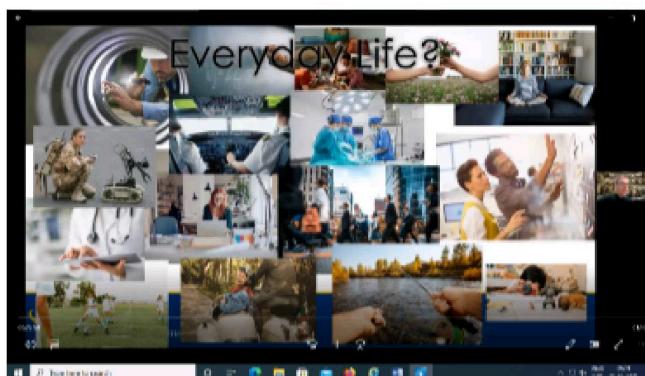
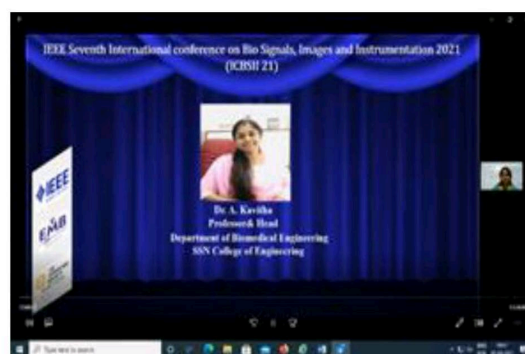
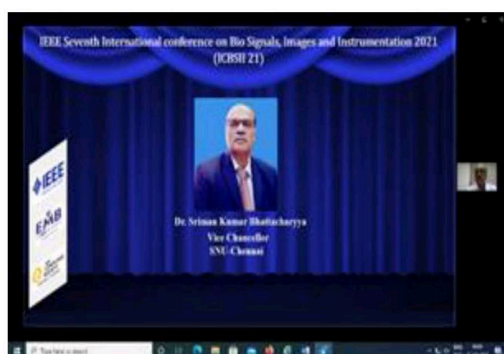
The IEEE Seventh International Conference of Biosignal, Images and Instrumentation 2021 (ICBSII 21) organized on March 25 – 27, 2021, brought together the chief guest, guests of honor, speakers and participants from various parts of the world. ICBSII 21 was held virtually, organized by the Department of Biomedical Engineering, Sri Sivasubramaniya Nadar College of Engineering. The event witnessed a great start due to the august presence of our President Dr. Kala Vijayakumar, President of Sri Sivasubramaniya Nadar Institutions, Pro Chancellor, Shiv Nadar University, Chennai, Dr. Sriman Kumar Bhattacharyya, Vice Chancellor of Shiv Nadar University, Chennai and Dr. V.E. Annamalai, Principal of Sri Sivasubramaniya Nadar College of Engineering.

The President, Dr. Kala congratulated the faculty and students of the department for conducting the seventh International conference successfully and appreciated the team for making it truly global with guests, speakers and participants from all over the globe. The Vice Chancellor of Shiv Nadar University, Chennai, expressed his happiness in being a part of the conference and mentioned that the young department is very impressive in terms of research accomplishments.

The conference had tremendous positive vibes and enthusiasm, spreading the same to the guests, speakers and the participants from almost all continents of the world. The Head of the Department Dr. A. Kavitha, the Chief guest, Guests of Honor, the Patrons, Guest Speakers and the participants, and invited everyone to indulge in interesting research findings to be discussed during the conference.

The keynote address was delivered by the expert members in various topics on Human Voice Analysis, Mental Health – Brain Stimulation, Biomechanics and Rehabilitation Engineering, Development of Medical Devices, and Clinical Engineering.

Dr. Hasan Ayaz, Cognitive and Quantitative Experimental Research Drexel University, USA was invited as chief guest for the inaugural function and Dr. Sriram Balasubramanian, Orthopedic Biomechanics, Drexel University, USA, Dr. Catherine Von Reyn, Neural Circuit Engineering Drexel University, USA, Dr. N. Kumarappan, Chairman, IEEE Madras section, Dr. G. S. Bhuvaneshwar, Consultant Medical Devices, Former Head, BMT, SCTIMST and Mr. R. Balamurugan, Sr Vice President, HCL Technologies, Chennai were invited as guests of honour for the inaugural function.





After months of hard work by the students of Sri sivasubramaniya Nadar college of Engineering, the technical fest Invente took place on the 22nd and 23rd of January 2021. This two day fest was inaugurated by the honorable Chief guest Dr. Srimathy Kesan, Founder and CEO Space kidz India along with dignitaries, the Principal, SSN college of engineering V. E. Annamalai and faculty members. The event began with an offering to the almighty by the students of the college. The chief guest then delivered an energetic address to the gathering, the talk was truly motivating and inspired the students to bravely venture into various interesting domains of research and start ups. The specially designed invente magazine - Tech Vibe was released by the chief guest. The whole proceeding was hosted by Mr. Anam Sathvik Reddy.



The college principal V.E. Annamalai with the presidents of each department.

During Invente 5.0, the set of roughly 60 events were conducted virtually by eight departments out of which, 8 events were conducted by The Biomedical Department. Out of the 8 events, we saw four technical events being conducted and four non-technical events including a workshop by the IEEE EMBS Society of our College.

Biomart, an event which brings out the fun entrepreneur among the participants saw close to 10 participants participating actively with innovative solutions. Medical Mystery, a biomedical quiz event and Dead Man's Chest, a fun non-technical event, both saw a healthy number of participants enthusiastically taking part.



Escape the Hill House, inspired by the very popular mystery maze saw a huge number of participants with close to 60 students taking part with a close finish! Min-E-Olympics, a fun filled non-technical event with several exciting mini games saw 21 teams combating each other with a high-adrenaline boost mode.

Paper Presentation saw 20 participants presenting their research work to our Professors, Dr. S Arun Karthick and Dr. S Bagyaraj who grilled the participants with their sharp technical acumen and decided the winners.

The Workshop conducted by the IEEE EMBS Society of our department saw over 50 participants enthusiastically attending the workshop on the trending topic of Space Biology.

Overall, the students of The Biomedical Department have put in their intense efforts and made this event a grand success.

### INVENTE BME TEAM :

**Ms. Dhanalakshmi M – Faculty Coordinator**

**The list of office bearers for the Association of Biomedical Engineers is as follows:**

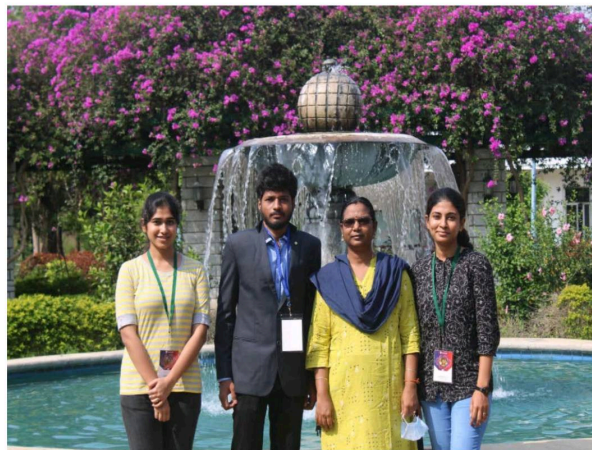
**Rajkumar A J - President**

**Varshini V – Vice President**

**Gurucharan M K - Secretary**

**Sharmilee S – Treasurer**

**Saranya V – Event coordinator**





**Faculty Coordinator with the Office Bearers**

## ACADEMIC COLLABORATIONS

3-Day  
Short Course on

# BIOMECHANICS



Offered by Experts from :  
Drexel University, USA and Nanyang Technological University, Singapore

Jointly Organised by :  
Department of Biomedical & Mechanical Engineering,  
SSN College of Engineering

DATE : 19 - 21 March 2018

VENUE : SSN College of Engineering, Chennai, India

The 3 day International Short Course on Bio-mechanics sponsored by DRDO was organised, between the 19th– 21st March, 2018 by the De-partment of Biomedical and Mechanical Engi-neering. 83 participants had enrolled for the course. Some of the experts present were Dr Sriram Balasubramanian, Drexel University, USA Dr Paul Brandt-Rauf, Dean, Drexel University, USA Dr Teo Ee Chon, Associate Professor, School of Mechanical and Aerospace Engineering, Nanyang Technological University (NTU), Singapore Dr G Sudhir, Spine Surgeon, SRMC Dr Dinesh Bhatia, Associate Professor and Head /BME, North Eastern Hill University, Shillong The program was coordinated by Dr A Kavitha (Head of the Department of Bio-medical Engineering), Dr M S Alphin (Associate Professor, Department of Mechanical Engineering) and Dr S Bagyaraj (Associate Professor, Department of Biomedical Engineering)

## SSN–DREXEL UNIVERSITY MS PROGRAM

This is Drexel University’s International Collaborative Master of Science Program with Sri Siva Subra-maniaNadar (SSN) College of Engineering. During this two-year program, the students will study the Drexel approved curriculum at SSN campus in Chennai, India in the first year. In the second year stu-dents land at Drexel University campus for the completion of remaining studies. The successful students would be awarded a Drexel MS degree in Biomedical Engineering.

### International MS in Biomedical Engineering

The SSN-Drexel University International Graduate Program in Biomedical Engineering offers an effi-cient path towards an MS degree.

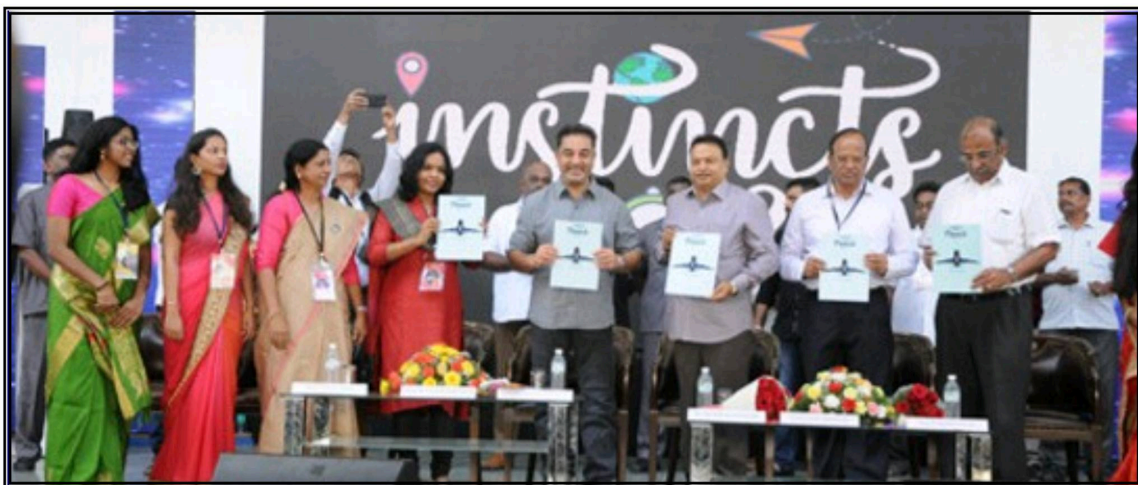
### MS Degree in Chennai - Program Overview

Once admitted, students begin their studies at SSN and transfer 15 credits to Drexel University at the end of their first year. In their second year, students continue their studies in biomedical engineering at Drexel University. After taking 30 credits of classes, SSN and Drexel credits are combined to award the student an MS degree in Biomedical Engineering.

## EXTRA CURRICULAR AND CO-CURRICULAR ACTIVITIES

### INSTINCTS

This is the cultural fest of the college, a three day extravaganza of fun and frolic in the month of March. The event has varying themes every year and all the students come together as volunteers, organisers and participants as well. This is one of the biggest Cultural Fests happen-ing in colleges all over India! The theme for the 14th version in March 2019, was 'Relive the 90's!' and for the 15th version during March 2020, was 'Lights Camera Action!'



### OTHER ACTIVITIES

Apart from organising the various events, the students of the department are part of various clubs of the col-lege including the Youth Red Cross (YRC), National Service Scheme (NSS), SSN Music Club, Dance club (N2K), English Literary Club,, Entrepreneurship De-velopment Cell Tamil Saral Mandram, Classical Dance Club, SSN Photography club and So on.



## INTERNALLY FUNDED PROJECTS (2019– 2020)

S NO	FACULTY IN-CHARGE	STUDENTS	TITLE OF THE PROJECT	AMOUNT
1.	Dr. Mrunal Deshpande	Chetana Krishnan R. (II Year) Sandhyavarshini (II Year)	Levitation of cells using homo mucous base	0.24L
2.	Ms. M. Dhanalakshmi	S. Anbu Selvi (ME - II Year) Praveen Surya (II Year) Abishek Dius (II Year)	Model and prototype of ankle foot orthosis for drop foot	0.24L
3.	Ms. M. Dhanalakshmi	T. Akshara Reddy (IV Year) Haridhra Suresh (III Year) J. Arthika (III Year)	Alternative foot brace for clubfoot correction	0.20L
4.	Ms. B. Divya	Bakhiyalakshmi (III Year) Samvardhini (III Year) Sivabaala (III Year)	Brainwave based wheelchair prototype	0.21L
5.	Dr. J. Vijay	A.R.Parvathi (III Year) B. Radhika S.(III Year) Shankharan (III Year)	Quantification and analysis of depression using brain waves	0.27L
6.	Dr. S. Arun Karthick Dr. L. Suganthi Dr. P. Balaji Bhargav	M. Logesh Kumar (II Year) R. Sherwin Robert (II Year)	Fabrication of stretchable impedance sensor using gold nanomesh	0.24L
7.	Ms. B. Divya	R. Shri Harini (III Year) A. Anusha (III Year) A.J. Rajkumar (III Year)	Wearable drowsiness detector	0.20L
8.	Dr. R. Subashini Dr. R. Govindaraj (SSN RC)	G. Poornima (II Year)	Synthesis and analysis of nanochitosan and silver nanoparticle incorporated glass ionomer cement	0.24L

**INTERNALLY FUNDED PROJECTS (2019– 2020)**

S NO	FACULTY IN-CHARGE	STUDENTS	TITLE OF THE PROJECT	AMOUNT
9.	Ms. R. Nithya	Divya Rajesh Kannan (II Year) Varsha Seshadri (II Year) Yuvasri Asokan (II Year)	Stress analysis using salivary cortisol levels	0.25L
10.	Dr. L. Suganthi	Sockalingam Saravanan (II Year) R. Bhargav (II Year)	IoT-Enabled health monitoring and assistive systems for elderly and disabled people	0.24L
11.	Dr. K. Nirmala Dr. L. Suganthi Dr. R. Govindaraj (SSN RC)	S. Sonali (III Year) P. Vanthana (III Year)	Biochemical sensing system for the detection of creatinine level	0.24L
12.	Dr. Sachin Gaurishankar Sarate Ms. M. Dhanalakshmi Dr. M. Anbu Selvi (ECE)	M.C. Sai Kavya Neharika (II Year) Rebecca Maria Gnanamuttu (II Year) P. Aishwarya Ponni (II Year) Meghna Govind (II Year)	Wireless charging of medical implants	0.24L

## INTERNALLY FUNDED PROJECTS (2018– 2019)

S NO	FACULTY IN-CHARGE	STUDENTS	TITLE OF THE PROJECT	AMOUNT
1.	Ms. R. Nithya	D Sutheshnna (III Year) T S Subhasri R Aarthi R Srinith (II Year)	An automatic writing stylus for the visually challenged	0.20L
2..	Dr. S. Bagyaraj	Prem Aravindhan Sandhanakrishnan-Durgadevi R Aishwarya (III Year)	Wearable device to detect Hypertension, Hypotension and Drug delivery system	0.10L
3.	Dr. Sachin Gaurishankar Sarate	Nanthini N Janaki R (IIYear)	Automatic eye drop dispenser	0.20L
4.	Dr. S. Bagyaraj	S Santhosh, Venkatakrishnan Sudharshan, R Saisrinivasan, Patrick A Joseph, S Prashanth (II Year)	EEG based brain computer interface for prosthetic hand control	0.25L
5.	Ms. M. Dhanalakshmi	SSrija, P Kawya (III Year)	Wearable reader for the visually impaired	0.20L
6.	Dr R Subashini	S Vishwanath(IV Year) Saranya, M Janani (II Year)	Portable power generating microbial fuel cell	0.22L
7.	Ms B Divya	Anupam Bhaskarbhata, Arvinth Swaminathan (III Year)	An ankle foot orthotic device integrated with a functional electrical stimulation unit to assist and improve walking for a foot drop	0.175L

# PATENTED PROJECTS



Ms. M. Dhanalakshmi M.E, Viswanath.S, Om Prakash S and Praveen kumar.G have filled a patent titled  
 “ A COMPOSITE BLADE FOR LOWER EXTREMITY AMPUTEES ”



Welcome to IPAIRS Version 2.0

Granted Patents | Published Applications | **Application Status** | Agent Register | Patent Registrar

Detail

APPLICATION NUMBER	6299/CHE/2015
APPLICANT NAME	SRI SIVASUBRAMANIYA NADAR (SSN) COLLEGE OF ENGINEERING
DATE OF FILING	24/11/2015 10:43:57
PRIORITY DATE	NA
TITLE OF INVENTION	MULTI-STANCE SMARTPHONE SUPPORT FOR MICROSCOPE
PUBLICATION DATE (IFS 11A)	25/03/2016

Application Status

Request For Examination Date	24/11/2015 10:43:59
Status	Application Awaiting Examination

[Print](#) [Track Report](#) [View Complete Specification](#) [View E-register](#) [View Examination Reports](#)  
[Orders/Decisions](#) [View Documents](#)

PATENT OFFICE  
 INTELLECTUAL PROPERTY BUILDING  
 G.S.T. Road, Guindy, Chennai-600032  
 Tel No. (091)044) 22502081-84 Fax No. 044 22502066  
 E-mail : Chennai-patent@nic.in  
 Web Site : www.ipindia.gov.in

CHALLAN : TR-5  
 DOCKET NO :21295

To,  
 THE PRINCIPAL  
 SRI SIVASUBRAMANIYA NADAR COLLEGE OF ENGINEERING, OLD MAHABALIPURAM ROAD, KALAVAKKAM,  
 TAMIL NADU - 603 110. dhanalakshimim@ssn.edu.in

Date/Time : 21/03/2018 03:03:01

Agent Number:

Sr. No.	CBR No.	Reference Number /Application Type	Application Number	Title/Remarks	Amount Paid
1	7819	ORDINARY APPLICATION	201841010368	AN EXTERNAL AID FOR AMYOTROPHIC LATERAL SCLEROSIS PATIENTS	8800
2		E-2/866/2018-CHE	201841010368	Form2	0
3		E-3/7013/2018-CHE	201841010368	Form3	0
4		E-5/447/2018-CHE	201841010368	Form5	0
<b>Total :</b>					<b>8800</b>

Received a sum of Rs. 8800 (Rupees Eight Thousand Eight Hundred only) through

Payment Mode	Bank Name	Cheque/Draft Number	Cheque/Draft Date	Amount in Rs
Cash	---	---	---	8800

Note: This is electronically generated receipt hence no signature required.



Ms. M. Dhanalakshmi M.E, Keziya M and Viswanath.S, have filled a patent titled  
 “ KNEE BRACE FOR GENU RECURVATUM ”



Dr A Kavitha (Head of the Department) and Ms R Nithya has filed a patent titled

FORM 3  
 THE PATENTS ACT, 1970  
 (39 of 1970)  
 &  
 The Patents Rules, 2003  
 STATEMENT AND UNDERTAKING UNDER SECTION 8  
 (see section 8, rule 12)

1. Name of the Applicants

We, Sri Sivasubramaniya Nadar College of Engineering, Indian Organization having our communication address at, OMR, Kalavakkam, Tamil Nadu – 603110, India hereby declare

2. Name, address and Nationality of Joint applicant

(i) that We have not made any application for the same/substantially the same invention outside India.

Name of the Country	Date of Application	Application No.	Status of the Application	Date of Publication	Date of Grant
NIL					

Dated this 6<sup>th</sup> day of August 2018

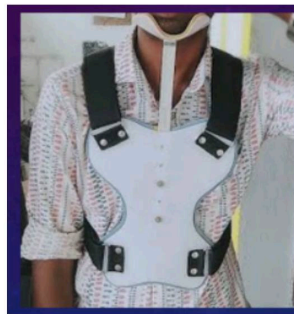
S. Sarin  
 For Sri Sivasubramaniya Nadar College of Engineering

To,  
 The Controller of Patents  
 The Patent Office, Chennai.



# PATENTED PROJECTS

<b>Title of the Patent: An external aid for amotrophic lateral sclerosis patients</b>
Inventors: <u>Viswanath, S, Praveenkumar, G, Dhanalakshmi, M</u>
Patent Application No: 201841010368
Month & year of Filing: 21.3.18
Month & Year FER was filed: Not yet
<b>Abstract:</b> Every year thousands of people get affected by Amyotrophic Lateral Sclerosis and drooping head conditions, that disable the people to have control over their head and neck extensor muscle. Commercially available supports impart four major hazards to the patients: suffocation, skin irritation, difficulty in swallowing, and neck soreness/pain. To reduce these adverse effects, a unique three-way support system that supports the head, neck, and chin is designed to arrest head movements such as flexion, extension, rotation and abduction. The proposed design is built incorporating essential biomechanics and ergonomics principles that provides required thrust in bringing the head upright with minimal stress zones. The system consists of a base panel, head panel and chin cap that are fabricated using polypropylene and the anterior and posterior support frames are fabricated using aluminum flat respectively. The supporting components are integrated using straps, made up of Nylon-Velcro material, facilitating effective head immobilization as well as easy portability. Coverings are provided with liner foam sheets that provide cushion support and protective covering for the users. Total deformation, safety factor and fatigue characteristics of the structural elements of the support are studied in a 3D modeling environment to understand the load distribution on the aid during actual usage through finite element simulations. No human data is collected during the simulation and all force acting on body is based on FEA simulation. The simulation results prove that the net force acting on the body-torso is negligible with minimal stress effects. This ensures all the mentioned hazards are greatly reduced in the proposed design in comparison with prior-arts.



An external aid for amotrophic lateral sclerosis patients

<b>Title of the Patent: AN ALTERNATIVE FOOT BRACE FOR CLUBFOOT CORRECTION</b>
Inventors: <u>S. Srija, P. Kawya, T. Akshara Reddy, M. Dhanalakshmi</u>
Patent Application No: Preliminary patent approved (10.3.2020)
Month & year of Filing: Not yet
Month & Year FER was filed: Not yet
<b>Abstract:</b> Clubfoot scientifically known as CTEV (Congenital Talipes Equino Varus), is a congenital disease condition where the child presents with either one foot or both the feet rotated internally at the ankle. The treatment is the ponseti method, including a casting phase and bracing phase. The casting phase is the initial treatment phase and is a crude method by itself followed by a tenotomy and the successive step is the bracing phase. The major drawbacks of the casting phase were that there was no specific gradual angle change and secondly the removal of the plaster using water leading to the baby falling ill. The project deals with replace the casting with an easier and more technical technique using a brace. To render an alternative foot brace in order to replace the series of casts and at the same time ensures a gradual change in the foot orientation angle. The principle behind the design of a brace is 3-point pressure principle and so that the deformity would be corrected by gradually changing the foot angle. Using 3D printing technology, the brace can be customizable and made as a product. The same brace ensures the gradual change in the foot orientation angle and nullifies the relapse of the foot. Materials taken for the study are Thermoplastic Polyurethane and Carbon fiber. Further, the material properties were studied and material testing is also involved.



An alternative foot brace for clubfoot correction

<b>Title of the Patent: An Embedded System Design for Non-Invasive Blood Glucose Measurement</b>
Inventors: <u>1. Dr. Suganthi 2. Hanpriya R 3. M. Nagavashini 4. Vignesh V 5. Vignesh R 6. Sriram Shreedharan 7. Vignesh R 8. A. S. Vikram 9. R. Jyothiraditya</u>
Patent Application No: 201941006594
Month & year of Filing: 20/2/2019
Month & Year FER was filed:
<b>Abstract:</b> The present invention explains about the non-invasive way of blood glucose, haemoglobin measuring device using Photo plethysmography (PPG) in the near infra-red range. The device measures the blood glucose and haemoglobin level based on the output of the detector. A clip-based device consists of a dual wavelength LED which acts as a light sensor and it is inserted into the finger of the individual.
The photoplethysmography is an optical technique that measures the pulse rate, arterial blood oxygen saturation and the blood volume changes and it uses a clip type device which contains a light source and a detector on the opposite sides to detect the cardiovascular pulse wave that propagates through the body. The photo-detector detects the incident light from the device and amplifies it with the help of an amplifier and it also converts the light into either current or voltage. Then, the amplified signal is sent to the microcontroller by converting the analog signal to the digital signal with analog to digital (ADC) converter. The microcontroller process the signal to determine the peak voltage. The final validation is done by comparing the obtained blood glucose and haemoglobin level results with the existing glucose and haemoglobin measurement methods. After comparing the results with the existing glucose and haemoglobin measurements, the voltage values are obtained and then it is converted to the equivalent glucose and haemoglobin values using regression equations and then the results are displayed in a OLED.



An Embedded System Design for Non-Invasive Blood Glucose Measurement

# PATENTED PROJECTS

<b>Title of the Patent: 3 D printed Prosthetic Arm</b>
Inventors: <u>Dr. A. Kavitha, Ms. R. Nithya,</u>
Patent Application No: 201941031286
Month & year of Filing:2/08/2019
Month & Year FER was filed: not yet
Abstract: The 3D printed prosthetic arm is a completely functioning artificial hand with 18 degrees of freedom which includes exclusive lateral movements of the fingers. The gear mechanism which allows lateral movements between various fingers is its main USP. Grasp, hold and squeeze operations of different sized objects are possible due to its high functional characteristics. The fingers are moved using servo motors and the functions are externally controlled.



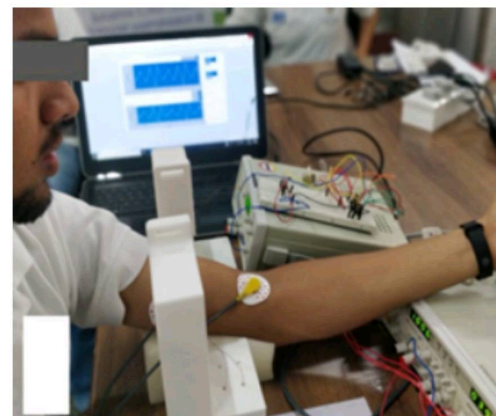
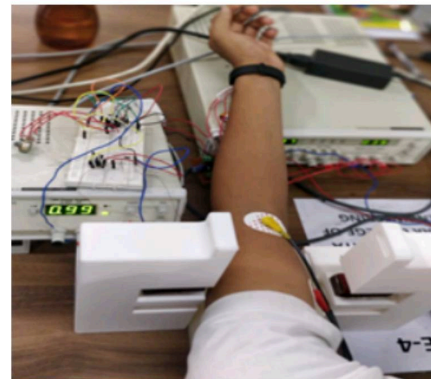
3 D printed Prosthetic Arm

<b>Title of the Patent: IMPLANTABLE BATON ANTENNA USING COPLANAR WAVEGUIDE (CPW) FEED</b>
Inventors: <u>Mahalakshmi N, Thenmozhi A, Vijay J</u>
Patent Application No: 201941035032
Month & year of Filing:30/08/2019
Month & Year FER was filed: Not Yet
Abstract:The scope of the present invention is defined solely by the appended claims and is not affected to any degree by the statements within this summary. The present embodiments may obviate one or more of the drawbacks or limitations in the related art. Embodiments provide a novel Implantable Baton Antenna for Medical Application. For this, the antenna should be designed with increase in reflection coefficient, and decrease in gain and it should be in the ISM band (Industrial, Scientific, Medical band). Generally the size of bio-medical antennas are large in size to obtain less amount of gain. Our proposed antenna design is for Implantable Baton antenna with CPW (coplanar waveguide) feed. The Antenna is constructed on substrate ROGERS 6010 to get the high dielectric constant (10.2). The antenna is designed with the size of 10x 10x0.365mm <sup>3</sup> . The total thickness of the antenna is 1mm. when compared to other biomedical antennas it is small and comfortable to use. The return loss of our antenna is -21.26 dB at a frequency range of 2.45 Ghz. For that we obtain a gain of -14.50dBi.when compared to other antennas this gain is low. The VSWR (Voltage standing wave ratio) for our designed antenna is below 2,we can conclude that the above implantable antenna is perfectly matched for the recent trend in diagnostic or therapeutic functions .



Implantable baton antenna using coplanar waveguide (cpw) feed

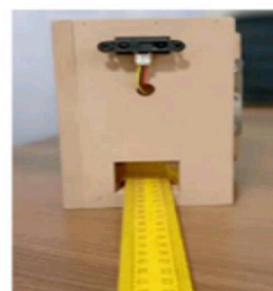
<b>Title of the Patent: Continuous Non-invasive blood pressure(NIBP) Measurement based on Electro-motive Force(EMF)</b>
Inventors: <u>GE Healthcare and SSN College of Engineering- Zuber Ahmed(GE), Dr.B Geethanjali, Saikiran S, Subashine S, Vishaal Venkat, Sriram V, Sabharish M, Varshmi V</u>
Patent Application No: 89324522
Month & year of Filing: 12.07.2019
Month & Year FER was filed: Not Yet
Abstract: The measurement of Blood pressure for years has been done by the auscultatory method, where a trained person inflates a cuff around the patient and identifies the highest and lowest values of pressure during the cardiac cycle and there is a growing need to create awareness and have the right means to calculate blood pressure. The idea is based on the principle of magnetic blood flow meter and when the arm placed inside the region of the magnetic field there is an EMF produced due to the flow of blood in the artery. The output of this stage is fed into the signal conditioning circuit and the final systolic and diastolic blood pressure values are obtained with maximal accuracy. The results were analyzed with the traditional sphygmomanometer and the digital sphygmomanometer which indicates that when miniaturized into compact models the device can measure blood pressure continuously and non-invasively and is capable of replacing the current cuff method as the accuracy of the device is maintained and errors were also in the tolerance range with minimal contact with the patient's skin.



Continuous Non-invasive blood pressure(NIBP) Measurement based on Electro-motive Force(EMF)

# PATENTED PROJECTS

<b>Title of the Patent:</b> Automated Weight Measurement Based on Anthropometry
<b>Inventors:</b> Kavya V Kannan, Kezia Sharon, Ananya, Vaishali, Arvind, Jagadesh, Mahesh V.
<b>Patent Application No:</b> 202041009649
<b>Month &amp; year of Filing:</b> March, 2020
<b>Month &amp; Year FER was filed:</b>
<b>Abstract:</b> Normally weight of the bed-based patients in the hospitals is estimated by visual approximation, previous records and by asking their family members which leads to medication errors and cause even death. Accurate weight measurement of the bed-based patients is required for the nutritionists so that they can prepare diet charts based on that.
A fitness enthusiast frequently estimates their weight in order to keep them fit and healthy. Most of the people and bed-based patients use load cell for measuring weights but the drawback in this system is it is more expensive, and installation of load cell is more difficult since the bed placed in the hospitals has to be designed accordingly.
The present invention describes a system to estimate the weight of the persons and even bed-based patients based on the anthropometry measurements. A body weight of the patients is estimated based on the anthropometric measurements such as knee to foot (KIF) length and middle upper arm circumference (MUAC) which is measured using an IR sensor. A formula for estimating the body weight using two anthropometric measurements is derived using regression analysis by correlating the knee to foot (KIF) length and middle upper arm circumference (MUAC) which is obtained from a wide range of population with weight. the body weight of the patient is measured by anthropometric methods through IR sensor, and the result is compared with the patients' actual weight. The project achieved accuracy of 95 % which was acceptable by doctors.



Automated Weight Measurement Based on Anthropometry

<b>Title of the Patent:</b> An enhanced carbon dioxide sorbent nanofibre membrane and a device thereof
<b>Inventors:</b> Thalappil Pradeep, Anagha Yatheendran, Ramesh Kumar, and Arun Karthick S
<b>Patent Application No:</b> 201841031076
<b>Month &amp; year of Filing:</b> 20/8/2018
<b>Month &amp; Year FER was filed:</b> 25/5/2020
<b>Abstract:</b> An AEAPTMS (N-[3-(Trimethoxysilyl) propyl] ethylenediamine) /aminoethyl-aminopropyl trimethoxysilane polyacrylonitrile (PAN) based electrospun nanocomposite material for CO <sub>2</sub> adsorption and air purification is proposed. The material has CO <sub>2</sub> capture capacity of 0.77 mmol/g at 24°C and 70% relative humidity or in air-conditioned environment with 100% regeneration capacity at near ambient temperature.

An enhanced carbon dioxide sorbent nanofibre membrane and a device thereof

<b>Title of the Patent:</b> Multi stance smartphone support for microscopes
<b>Inventors:</b> S. Saravana Prakash, S. Pravin Kumar and S. Rajendiran
<b>Patent Application No:</b> 6299/CHE/2015
<b>Month &amp; year of Filing:</b> 24/11/2015
<b>Month &amp; Year FER was filed:</b> 26/06/2019
<b>Abstract:</b> The present invention is a multistance smartphone support for microscopes which discloses a support for the smartphone to connect with microscopes of different makes. More particularly, this invention relates to a versatile multi stance support, which can be adapted to different positions that avoids hand jerks associated with conventional frames. The present invention can be used with all types of smartphones and microscopes. More importantly, the device will be useful to take images and videos for presentation to the scientific community, clinical and academic laboratory-setup which includes human, animal and plant physiology, anatomy and pathology labs where microscopic examination of processed tissue of human and non-human sources is carried out for teaching and research purposes in addition to diagnostic work up. This invention provides a stable, flexible, and convenient fixation of smartphone for efficient pathological examinations, thereby reducing the fixation timings and parfocality optical errors associated with improper hand supported mounting.

Multi stance smartphone support for microscopes

## PATENTED PROJECTS

S.No	Inventors Name	Title	Ref No	Year Filed	Year published
1	Viswanath. S, Praveenkumar. G, Dhanalakshmi. M	An external aid for amyotrophic lateral sclerosis patients	201841010368	21.3.18	06/04/2018
2	Viswanath. S, Apurva, Subhashini R	Orthopaedic Belts using Sodium Acetate Crystals	201841038594	2018	19/10/2018
3	S. Saravana Prakash, S. Pravin Kumar and S. Rajendiran	Multi stance smartphone support for microscopes	6299/CHE/2015	24/11/2015	25/03/2016
4	Delpha and Abirami	Mass screening device for Osteoarthritis	201741013467	17.04.2017	26.10.2018, FER - 18.09.2020
5	Gobi N and Arun Karthick S	Multifunctional nanocomposite nanofibrous filter for aerosol filtration, chemical and biological protection	201841029428	6/8/2018	17/8/2018
6	Thalappil Pradeep, Anagha Yatheendran, Ramesh Kumar, and Arun Karthick S	An enhanced carbon dioxide sorbent nanofiber membrane and a device thereof	201841031076 & PCT/IN2019/05 0555	20/8/2018	31/8/2018
7	Dr. Suganthi, Haripriya R, M. Nagavarshini, Vignesh V, Vignesh R, Sriram Shreedharan, Vignesh R, A.S.Vikram, R.Jyothiraditya	An Embedded System Design for Non-Invasive Blood Glucose Measurement	201941006594	20/2/2019	11/09/2020

## PATENTED PROJECTS

9	Viswanath.S, Praveen Kumar G, Om prakash S, Dhanalakshmi M	Composite blades for lower extremity amputees	201941031300	2019	5/2/2021
10	Viswanath S, Kesiya M, Dhanalakshmi M	A knee brace for Genu recurvatum	201941021288	08.02.2019	5/2/2021
11	Kavitha Anandan, Nithya R, Omar Saleh	3 D printed Prosthetic Arm	201941031286	08.02.2019	5/2/2021
12	Mahalakshmi N, Thenmozhi A, Vijay J	Implantable Baton Antenna Using Coplanar Waveguide (CPW) Feed	201941035032	30.08.2019	5/3/2021
13	GE and SSN college of Engineering(Industry and Academia)	Continuous Non-invasive blood pressure(NIBP) Measurement based on Electro-motive Force(EMF)	89324522	12.07.2019	Not yet
14	Kavya V.Kannan, Kezia Sharon, Ananya, Vaishali, Arvind, Jagadesh, Mahesh V.	Automated Weight Measurement Based on Anthropometry	202041009649	06.03.2020	24.4.2020
15	Preethi Kurian, Vijay Jeyakumar	Unsupervised Multimodality Medical Image Retrieval System	202041043275	05.10.2020	16.10.2020
16	S. Subashini, S N Jaya Sree, Vijay Jeyakumar, Nirmala K	Smart Phone enabled Dermatoscope for Automated Skin Lesion Classification using Convolutional Neural Network	202041043279	05.10.2020	16.10.2020

## MOUs



## HIGHER STUDIES

### USA



### SINGAPORE



### AUSTIN



### EUROPE



## RESEARCH GROUPS



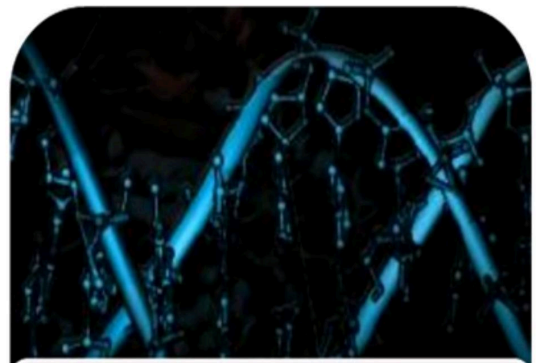
**Cognitive Neuroscience**



**Medical Signal & Image Processing**

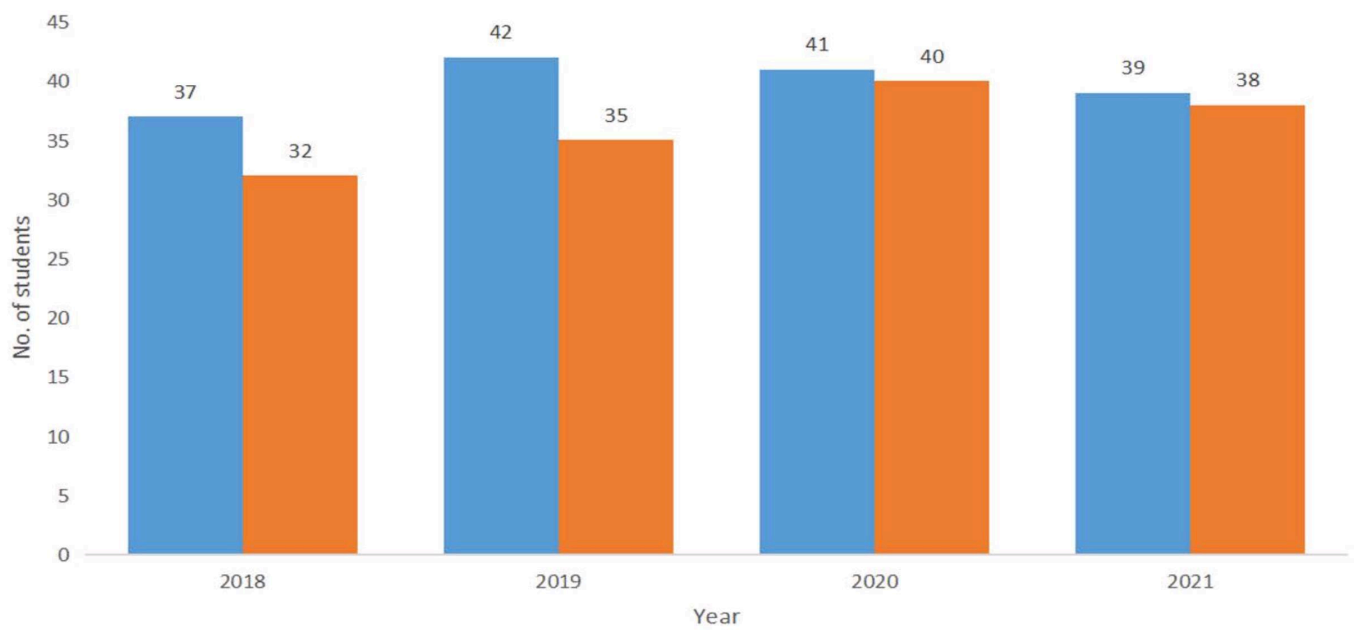


**Medical Devices & Instrumentation**



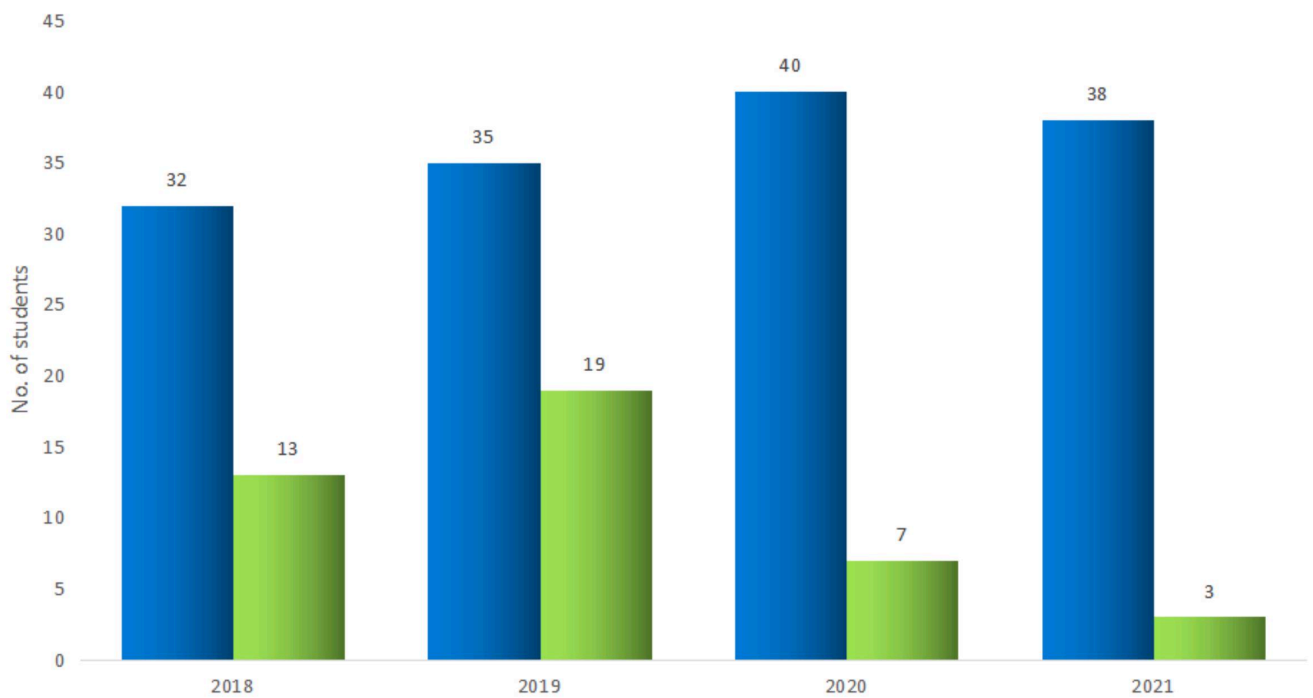
**Bioengineering**

# PLACEMENTS AND HIGHER STUDIES



Values

■ Number of Eligible Students ■ Total number of students placed



Values

■ Students who got placed ■ Students who opted for higher studies





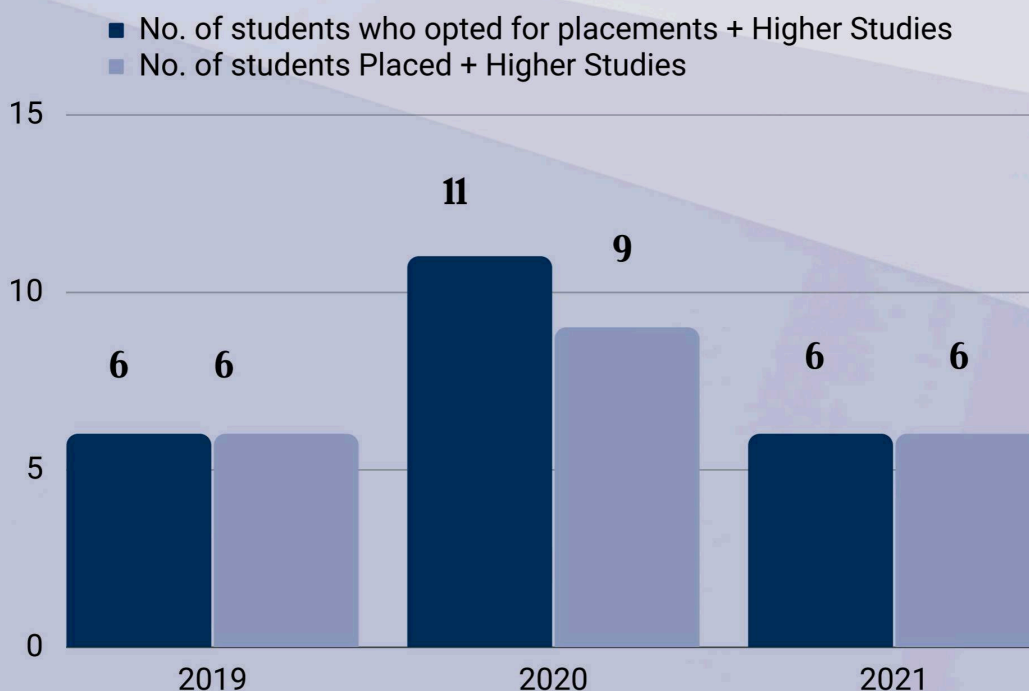
# PLACEMENT STATISTICS

## PG PLACEMENT ACTIVITIES

The students of PG medical electronics get placement in core biomedical companies by demonstrating their project work. . Our students received opportunities to work in various project domains and gained substantial knowledge in their domain of interest to extend their work further towards research. Consequently, they were offered Junior research fellowship in externally funded projects and higher studies opportunities as full-time Ph.D. scholars in India as well as abroad .

The students of M.E Medical Electronics get placements every year from core companies relevant to the biomedical field and regular companies as well. An increase in the number of students placed during every consecutive academic year can be seen in the following statistics .

The focus of our students are either core company placement or options for higher studies in the biomedical field abroad. Our students get placement in core companies such as HCL Healthcare, Allyshealth, Keyence, Phoenix Medical Systems, etc., as well as in regular companies and academic institutions.



## **PLACEMENTS AND HIGHER STUDIES**

**This year's placements began with a great amount of energy from the students, placement cell and First off, Super dream companies started coming followed by core companies, and dream companies. The students of the department of Biomedical Engineering have proved themselves in the past three months by setting a good placement record.**

**The first company where our department student got placed is LTI - Larsen & Toubro Infotech, which is a global technology consulting and digital solutions company for the position of Data Analyst. This came under Dream companies that offered a relatively high salary package considering Regular offers. This was followed by offers from Dream companies like TCS, ZoomRx where more than one got placed in analyst positions. Another Dream company, Accenture, recruited two students for the role of Engineer.**

**Thus grew the impetus and enthusiasm shown to placements by our students and faculty. Next up was a core company called Zifo R&D which is a pharmaceutical research oriented company. Ten students bagged offers after a rigorous interview process that had more than three stages of interviews. This was followed in parallel by the campus process of HCL, where another ten students got placed for Trainee roles.**

**Some of the regular offers included recruitment of two students for Infosys, around seven for Cognizant, two for Future Generali and one for Freshworks. Other recruiters that came for placements included Visionary RCM, Leadquared, Preludesys India, Facilio, Boxfile, Aspire Systems, Zoho & Latent View.**

**Despite the unfortunate Covid-19 scenes, placements for the year 2020 have been relatively high and promising. It is also to note that many students have pursued a future with higher studies and many with their own paths to success in various fields.**

## ALUMNI



Mohamed Irfan M R  
PhD Student  
Biomedical Signals and Systems  
University of Twente,  
The Netherlands

Biomedical Engineering at SSN gave me an interesting perspective on future prospects and the different options I could take. The basics I learnt here were fruitful in defining my career path. The job scenario for biomedical engineering is still evolving in India, and SSN places you at the right cross roads of talent, and networking. So, please make the most of the four years of your bachelor's. You will not only end up with a good vision for your career, but also gain a good family on the way.

Batch: 2008-2012  
Program: B.E Biomedical Engineering.  
Department: Biomedical Engineering

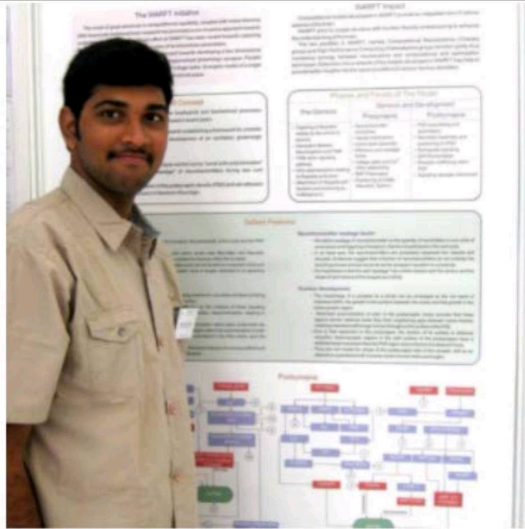


N P Guhan Seshadri  
Research Scholar  
Department of Biomedical Engineering  
National Institute of Technology Raipur  
Chhattisgarh, India

The best learning phase in my career so far happened to me at SSN. The two years I spent at SSN taught me immense lessons in my research career and raised my confidence level. The faculties at Dept of BME are so encouraging, friendly and some of them are best in this field. They showed me the real excitement in learning new techniques that would help in healthcare needs. I would also advise my juniors and the incoming students to use the maximum potential of the faculties here. Trust me the practical knowledge you will gain at BME laboratories will help you forever in your career. I got the best supervisor and mentor, under their guidance I have published around 4 research articles in IEEE journal and other reputed biomedical journals. This has largely helped me in pursuing my PhD at NIT Raipur with Institutional scholarship.

Batch: 2014-2016  
Program: M.E in Medical Electronics  
Department: Biomedical Engineering

## ALUMNI TALK



M. Kapardi,  
Research Scholar  
Spine Labs  
Department of Biomedical Engineering  
IIT, Hyderabad.

*"SSN is one of the few institutions in our country which offers courses in Biomedical Engineering. I would like to thank my mentor Dr. Kavitha and other faculties in the department for not only shaping up my career but also for imparting great values in me. The environment in the campus boosted my morale and encouraged me towards research. A special mention to the library of the institution, it never ceases to amaze you."*

Batch: 2015-2017  
Program: M.E in Medical Electronics  
Department: Biomedical Engineering



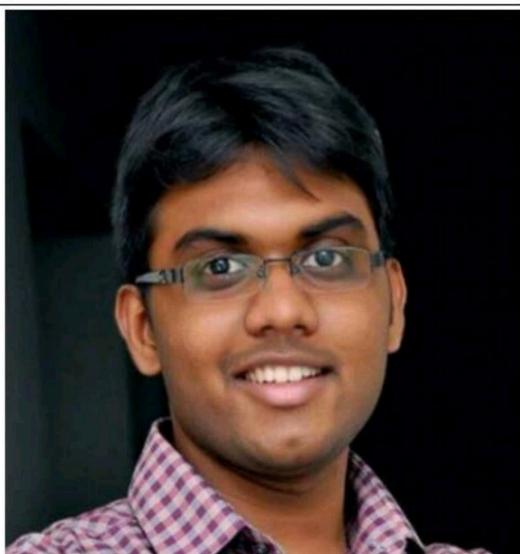
P. Vardhini  
Research Scholar,  
Non-Invasive Imaging and Diagnostics  
Laboratory,  
Indian Institute of Technology Madras.

### **My experience at SSNCE:**

I feel very proud to say that I pursued both my bachelor's and master's degree in the Biomedical Engineering Department. Throughout the journey of my college life, SSNCE supported and encouraged me to give my best. This college provided me with a platform to acquire academic knowledge as well as life skills. The BME department offered me various opportunities for my personal and professional growth. The experience I gained from my project work and laboratory courses helped me to improve my technical skills. All the valuable teachings and life lessons imparted by my mentors have been so enriching. I wish to express my sincere thanks to all my professors and faculty members of the BME department who led me through, supported me, and believed in me. My life at SSN was a memorable and amazing experience which I will cherish forever in my life.

Batch: 2015-2017  
Program: M.E in Medical Electronics  
Department: Biomedical Engineering

## ALUMNI



Vignesh Baskaran  
Data Scientist, Darts-ip  
Master of Artificial Intelligence,  
KU Leuven,  
Belgium.

Definitely one of the best things that happened to me is to study at SSN. I enjoyed a wonderful time in the BME department with the freedom to be creative and the guidance to be innovative! I learnt the art of conducting scientific research here and it helps me everyday in my career! I am definitely grateful to all the Professors at the department!

Batch: 2010-2014  
Program: B.E in Biomedical Engineering  
Department: Biomedical Engineering



Prasanna Vijayarangan  
Senior Systems Engineer  
Molecular Imaging  
Siemens Healthineers, Bangalore

BME at SSN is a complete package c one's expectations of a bachelor's degree. The faculty here has always catered to the needs of the aspirants, guiding and molding us to be innovative, hence bringing out the best in us. The learning opportunities at SSN are abundant! These, when put to use in the right manner, have not only helped us technically but also in our professional life in the corporate environment. With the healthcare industry in boom the landscape of job opportunities has changed drastically, a degree in BME is not limited to job opportunities in hospitals and software industries. There are a lot of healthcare manufacturing industries coming up from the top players in India! Young BioMedical Engineers are positioned to succeed!

Batch: 2009-2013  
Program: B.E Biomedical Engineering.  
Department: Biomedical Engineering



## **COLLEGE DETAILS:**

### **CAMPUS :**

SSN Institutions, Old Mahabalipuram Road,  
Kalavakkam-603110, TamilNadu, India.

Phone: 044-27469700

Telefax: 044-27469772

Email: [info@ssn.edu.in](mailto:info@ssn.edu.in)

### **ADMINISTRATIVE OFFICE:**

SSN Educational & Charitable Trust,  
211/95, V.M. Street, Mylapore, Chennai-600004

Phone: 044-24986474 / 044-24982656

Fax: 044-24982656

### **DEPARTMENT OF PLACEMENT & TRAINING**

Phone: 044-27469700

